

COMPACT-CLASS EXCAVATORS

ZAXIS

DASH-5

ZX17U-5

ZX26U-5



HITACHI

EXCAVATOR DRIVEN. NEVER SIDETRACKED.

EXCAVATOR FOCUSED. NO DISTRACTIONS.

Decades ago Hitachi built the first hydraulic excavator in Japan. That legacy of innovative technology continues today, delivering unmatched efficiency, reliability and durability day after day. The result? You get an excavator that starts when you do and doesn't know the meaning of the word "quit."

Although they are the smallest of our excavators, the ZX17U-5 and ZX26U-5 give you big-time performance on all kinds of jobs. These tiny titans are nimble and designed to keep their tails close to their tracks so you can easily work in tight spaces. Fuel-efficient Yanmar engines that meet EPA Final Tier 4(FT4)/EU Stage IV emission standards provide reliable and powerful performance. Spacious cabs with wider, easier entry and better visibility won't cramp your style. And maintenance is easy thanks to enhancements such as improved access to coolers. When you choose Dash-5 Compact Excavators you get...

BIG-TIME PERFORMANCE.





HITACHI

SPECIALISTS

ZX17U-5 / ZX26U-5

ZAXIS | DASH-5 COMPACT-CLASS EXCAVATORS

PRODUCTIVITY





MORE PRODUCTIVITY **IN MORE PLACES.**

A SIZABLE IMPACT ON PRODUCTIVITY.

No doubt about it. With their reduced-tail-swing design, these compact, yet powerful excavators are perfect for work in congested or confined areas. But they're not just close-quarters contributors. Easy to load and transport between jobs, these highly capable overachievers are also smart choices for trenching, excavating, loading trucks and other tasks in wide-open spaces. And fuel-efficient Yanmar FT4 engines are impressively quiet. When you've got these compacts on your team, you can...

WORK ANYWHERE, ANYTIME.

- With independent swing boom and 360-degree rotation, obstacles won't get in the way of your work.

- Standard backfill blade adds versatility, enabling these compacts to grade and backfill, as well as provides extra stability.

- The variable-width undercarriage and foldable blade on the ZX17U-5 can be hydraulically retracted to navigate tight quarters, then easily repositioned for solid stability.

- Versatile rubber tracks minimize ground damage and allow machines to cross virtually any terrain, including paved surfaces.

COMFORTABLE CABS MAKE FOR PRODUCTIVE OPERATORS.

COMFORTABLE, SAFE AND EFFICIENT.

Just because our machines squeeze into tight spaces doesn't mean operators should. These compacts come standard with a canopy that meets the ISO standard for rollover protective structure (ROPS) certification. For cold-weather comfort and productivity, the ZX26U-5 is available with an enhanced, heated cab. Our spacious operator stations won't cramp your style with wide entryways and generous legroom. Unmatched visibility, low-effort controls plus other features allow operators to...

FOCUS ON PRODUCTIVITY.



■ Go from backhoe- to excavator-style controls with just a twist of your wrist. Control-pattern selector valve is conveniently located in a compartment beneath the seat and includes a sight glass that displays the selected pattern.



■ Ergonomically correct short-throw pilot levers provide smooth, precise control with less effort.



■ Swing boom and foldable travel pedals on the ZX26U-5 are positioned where they're easy to operate, yet allow plenty of foot room.



■ Redesigned blade extension pins allow you to effortlessly expand the width of the blade to match the track width on the ZX17U-5.

COMFORT



■ Track speeds automatically slow to low whenever a heavier load is encountered and then return to high when the load normalizes. No pedal or operator activation is required for ZX26U-5 high-speed travel.

■ Easy-to-read upgraded display shows operating information, hours and fuel level at a glance.

■ Flat, skid-resistant floor mats remove easily for clean-out.

■ The durable, redesigned cab meets the ISO standard for rollover protective structure (ROPS) certification.

■ Spacious operator stations have wide entryways, making entering and exiting the cab easier than ever.

DURABILITY



Oil-impregnated bushings enhance durability and extend grease intervals to 500 hours for the arm-and-boom joint and 100 hours for the bucket.

Wet-disc swing brake provides long-term maintenance-free performance.

Heavy-duty side shields deflect material and impacts, protecting the propel motors and boom and blade cylinders.

O-ring face-seal hydraulic fittings virtually eliminate aggravating and costly oil leaks.



TOUGH ENOUGH FOR YOUR TOUGHEST JOBS.

STRONG-ARMED PERFORMANCE.

Just like our large excavators, toughness is built into these tiny titans with a heavy-duty undercarriage and durable side shields. A tough X-frame provides a rock-solid base, and oil-impregnated bushings add strength and extend grease intervals. Add it all up, and you get...

DURABILITY YOU CAN DEPEND ON.



■ Unique steel cores within rubber tracks resist cracking, and large-diameter drive sprockets and track idlers make for a rock-solid undercarriage.



■ Steel hydraulic lines are clamped securely, and wear-resistant hoses are protected with Cordura® covering.



■ Heavy-duty X-frame provides a solid, stable platform that resists material build-up.



■ Manual wedge-style coupler enables quick changes and a wide variety of buckets and attachments, such as breakers and augers.

LESS MAINTENANCE. MORE UPTIME.

LOWER OPERATING COSTS.

The ZX17U-5 and ZX26U-5 are equipped with time-saving and productivity-boosting advantages — from grouped service points to at-a-glance gauges. An additional steel door provides improved access to the side-by-side cooling cores. Extended service intervals minimize daily operating costs. All these features make Dash-5 excavators easy to work with and...

EASY TO MAINTAIN.

■ Yanmar diesel engines meet EPA Final Tier 4 (FT4)/EU Stage IV emission regulations. Easy to maintain, they require no aftertreatment device.

■ Routine checks such as engine oil level are quickly accomplished from ground level.

■ Side-by-side cooling cores resist trash buildup, and an additional steel door provides improved access for efficient cleaning.

■ Hydraulic fluid sight gauge and see-through coolant reservoir let you quickly check levels at a glance.

■ Spin-on filters make fluid changes quick, and extended oil intervals let you work longer.





HITACHI

EFFICIENT

ZX26U-5

Engine	ZX26U-5	
Manufacturer and Model	Yanmar 3TNV80F	
Non-Road Emission Standard	EPA Final Tier 4 / EU Stage IV	
Displacement	1.267 L (77 cu. in.)	
Net Power (ISO 9249)	14.9 kW (20.0 hp) at 2,500 rpm	
Powertrain	Each track independently driven by hydrostatic axial-piston motor connected to 2-stage planetary gear-reduction box	
Maximum Travel Speed		
Low	2.9 km/h (1.8 mph)	
High	4.5 km/h (2.8 mph)	
Swing Speed	9.1 rpm	
Swing Brake	Spring applied, hydraulically released, automatic	
Hydraulics	Open center with 2 variable-displacement pumps, 1 fixed-gear pump and 1 pilot pump	
Pump flow		
Piston	2 x 36.0 L/m (2 x 7.9 gpm)	
Gear	16.28 L/m (4.3 gpm)	
Auxiliary Flow	46.18 L/m (12.2 gpm)	
Controls	Hydraulic pilot operated for boom, arm, bucket, swing, boom swing, blade, travel, and auxiliary functions	
Electrical	Alternator Rating 40 amp	
Work Lights	2 Halogen: 1 mounted on operator station and 1 mounted on boom	
Undercarriage	2-speed axial-piston propel motors	
Tracks, Rubber	300 mm (12 in.)	
Ground Pressure with 1.17-m (3 ft. 10 in.) Standard Arm, Standard Counterweight and Rubber Track		
Canopy	25.0 kPa (3.6 psi)	
Cab	25.9 kPa (3.8 psi)	
Upperstructure	Independent Swing Boom with 1.17-m (3 ft. 10 in.)	
Standard Arm	<i>Canopy and 241-kg (531 lb.) Standard Counterweight</i> <i>Cab and 208-kg (459 lb.) Standard Counterweight</i>	
Left	70 deg.	70 deg.
Right	60 deg.	60 deg.
Serviceability	Refill Capacities	
Fuel Tank	34.07 L (9.0 gal.)	
Cooling System	3.12 L (3.3 qt.)	
Engine Oil with Filter	3.69 L (3.9 qt.)	
Hydraulic Tank	23.85 L (6.3 gal.)	
Operating Weights	With 1.17-m (3 ft. 10 in.) Standard Arm, Rubber Track, Standard Counterweight, Full Fuel Tank and 79-kg (175 lb.) Operator	
Canopy	2620 kg (5,780 lb.)	
Cab	2770 kg (6,110 lb.)	

SPECS

Operating Dimensions

ZX26U-5

1.17-m (3 ft. 10 in.) Standard Arm and Standard Counterweight

	Canopy	Cab
A Maximum Digging Reach	4.63 m (15 ft. 2 in.)	4.63 m (15 ft. 2 in.)
B Maximum Digging Depth	2.59 m (8 ft. 6 in.)	2.59 m (8 ft. 6 in.)
C Maximum Cutting Height	4.44 m (14 ft. 7 in.)	4.28 m (14 ft. 1 in.)
D Maximum Dumping Height	3.19 m (10 ft. 6 in.)	3.04 m (10 ft.)
E Transport Height	2.43 m (8 ft.)	2.43 m (8 ft.)
F Overall Length		
Blade in Front	4.18 m (13 ft. 9 in.)	4.18 m (13 ft. 9 in.)
Blade in Rear	4.48 m (14 ft. 8 in.)	4.48 m (14 ft. 8 in.)
G Minimum Swing Radius	1.92 m (6 ft. 4 in.)	2.01 m (6 ft. 7 in.)
H Blade Bottom Highest Position	0.32 m (13 in.)	0.32 m (13 in.)
I Blade Bottom Lowest Position	0.32 m (12 in.)	0.32 m (12 in.)
Boom-Swing Pivot Offset Distance	0.09 m (3 in.)	0.09 m (3 in.)
Offset Distance		
Left	0.56 m (22 in.)	0.56 m (22 in.)
Right	0.70 m (28 in.)	0.70 m (28 in.)
Digging Force		
Bucket	22.21 kN (4,994 lb.)	22.21 kN (4,994 lb.)
Arm	15.17 kN (3,410 lb.)	15.17 kN (3,410 lb.)

Machine Dimensions

Blade		
Width	1.50 m (4 ft. 11 in.)	
Height	320 mm (12.6 in.)	
1.17-m (3 ft. 10 in.) Standard Arm and Standard Counterweight		
J Upperstructure Width	1.39 m (4 ft. 7 in.)	1.42 m (4 ft. 8 in.)
K Overall Height	2.43 m (8 ft.)	2.43 m (8 ft.)
L Rear-End Swing Radius	0.80 m (31 in.)	0.80 m (2 ft. 7 in.)
M Minimum Ground Clearance	0.30 m (12 in.)	0.30 m (12 in.)
N Counterweight Height	0.53 m (21 in.)	0.53 m (21 in.)
O Engine Cover Height	1.49 m (4 ft. 11 in.)	1.47 m (4 ft. 10 in.)
P Undercarriage Length	1.96 m (6 ft. 5 in.)	1.96 m (6 ft. 5 in.)
Q Undercarriage Width	1.50 m (4 ft. 11 in.)	1.50 m (4 ft. 11 in.)
R Sprocket Center to Idler Center	1.53 m (5 ft.)	1.53 m (5 ft.)
S Track Shoe Width	0.30 m (12 in.)	0.30 m (12 in.)

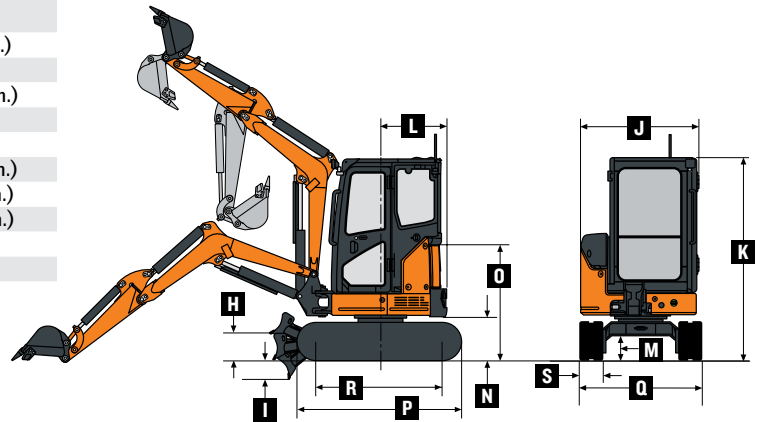
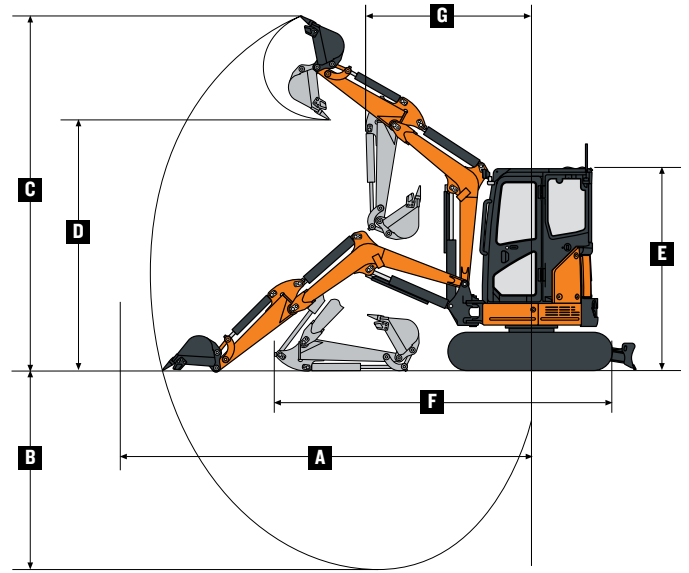

Lifting Capacities

1.17-m (3 ft. 10 in.) Standard Arm, Standard Counterweight, and Rubber Track

	Canopy		Cab	
	Over Front*	Over Side	Over Front*	Over Side
Ground Level at 3.0-m (10 ft.) Radius	1200 kg (2,573 lb.)	362 kg (781 lb.)	1201 kg (2,592 lb.)	394 kg (850 lb.)

*Blade down (limited by hydraulics).

SPECS

ADDITIONAL EQUIPMENT

Key: ● Standard ▲ Optional or special kit

17	26	Engine
●	●	Meets EPA Final Tier 4/EU Stage IV emissions
●	●	Engine coolant to -37 deg. C (-34 deg. F)
●	●	Engine preheater
●	●	Fan guard
●	●	Fuel/water separator
●	●	Full-flow oil filter
●	●	Isolation mounted
●	●	Key start switch with electric fuel shutoff
●	●	Single dry-type air filter
●	●	Under-hood muffler
Hydraulic System		
●		Auxiliary function foot control
●	●	Auxiliary function right-hand pilot-lever control
●	●	Auxiliary hydraulic lines to end of boom
●	●	Auxiliary return-flow selector valve
●	●	Axial-piston swing motor
●	●	Boom-swing foot control
●	●	Excavator-to-backhoe control pattern change valve
●	●	Open center with 2 variable-displacement pumps, 1 fixed-gear pump and 1 pilot pump
●	●	Hydraulic pilot-operated controls for boom, arm, bucket, swing, boom swing, blade, and travel
●	●	Wet-disc swing brake
Undercarriage		
●		Hydraulic-adjustable variable width
●	●	Planetary final drive
●	●	Propel motor shield
●	●	2-speed axial-piston propel motors
●		Rubber track, 230 mm (9 in.)
●		Rubber track, 300 mm (12 in.)

17	26	Upperstructure
●	●	360-deg. rotation
●		Counterweight, 120 kg (265 lb.)
●		Counterweight, cab, 208 kg (459 lb.)
●		Counterweight, canopy, 241 kg (531 lb.)
●	●	Hinged service-access doors
●	●	ROPS/TOPS/FOPS (canopy)
▲		ROPS/TOPS/FOPS cab with heater
●	●	Vandal protection for service doors and fuel cap
●	●	Reduced-tail-swing configuration
Front Attachments		
●		Arm, 0.93 m (3 ft. 1 in.)
●		Arm, 1.17 m (3 ft. 10 in.)
●		Backfill blade, 0.98 m (3 ft. 3 in.) minimum to 1.28 m (4 ft. 2 in.) maximum
●		Backfill blade, 1.50 m (4 ft. 11 in.)
●		Boom, 1.82 m (6 ft.)
●		Boom, 2.10 m (6 ft. 11 in.)
●	●	Mechanical quick-coupler
▲		Augers: Chain drive / Bits / Bit adapters
▲		Augers: Planetary / Chain drive / Bits / Bit adapters
▲	▲	Clamp
▲	▲	Hammers: Points / Tools
▲	▲	Quick-coupler buckets: Bucket teeth / Ditching / Heavy-duty

17	26	Operator's Station
●	●	Horn
●	●	Hour meter
●	●	Instrumentation lights
●	●	Monitor system: Preheat indicator / Engine oil pressure warning light / Alternator charge warning light / Fuel gauge and low-fuel-level indicator / Engine coolant warning light and alarm / Hour meter / Work lights indicator
●	●	Motion alarm with cancel switch
●	●	Work lights switch
●		Propel levers
●		Propel levers and foldable pedals
●		2 travel speeds
●		2 travel speeds with automatic shifting
●	●	Seat belt, 51 mm (2 in.), retractable
●	●	Vinyl seat with fore/aft adjustment (canopy models only)
●		Suspension seat
▲	▲	Front screen
Electrical		
●	●	12-volt accessory outlet
●	●	Alternator, 40 amp
●	●	Low-maintenance battery
●	●	Blade-type multi-fused circuits
●	●	Positive-terminal battery covers
Lights		
●		Work lights: 1 mounted on boom
●		Work lights: Halogen / 1 mounted on operator's station / 1 mounted on boom

See your Hitachi dealer for further information.

Net engine power is with standard equipment including air cleaner, exhaust system, alternator, and cooling fan at test conditions per ISO 9249. These machines are not equipped with spark-arrestor mufflers. Usage in forestry applications is not recommended. Specifications and design subject to change without notice. Wherever applicable, specifications are in accordance with SAE standards. Except where otherwise noted, these specifications are based on canopy units with standard arms; full fuel tanks; and 79-kg (175 lb.) operators; a 17U unit with 406-mm (16 in.) bucket, 230-mm (9 in.) rubber track, and 120-kg (265 lb.) counterweight; and a 26U unit with 457-mm (18 in.) bucket, 300-mm (12 in.) rubber track, and 208-kg (459 lb.) cab counterweight or 241-kg (531 lb.) canopy counterweight.

HITACHI

hitachiconstruction.com