



THE STRENGTH WITHIN

C JOIST SPAN TABLES AND DETAILS



MONTREAL • TORONTO • CALGARY • EDMONTON • VANCOUVER

BAILEY[®]
METAL PRODUCTS LIMITED



FLOOR JOISTS

Bailey Lightweight Steel Framing (LSF) Joists offer a wide range of span and load capabilities for commercial and residential floor systems and mezzanines. The use of Bailey LSF Joist Rafter members will provide support for interior drywall ceilings where long clear spans are required.

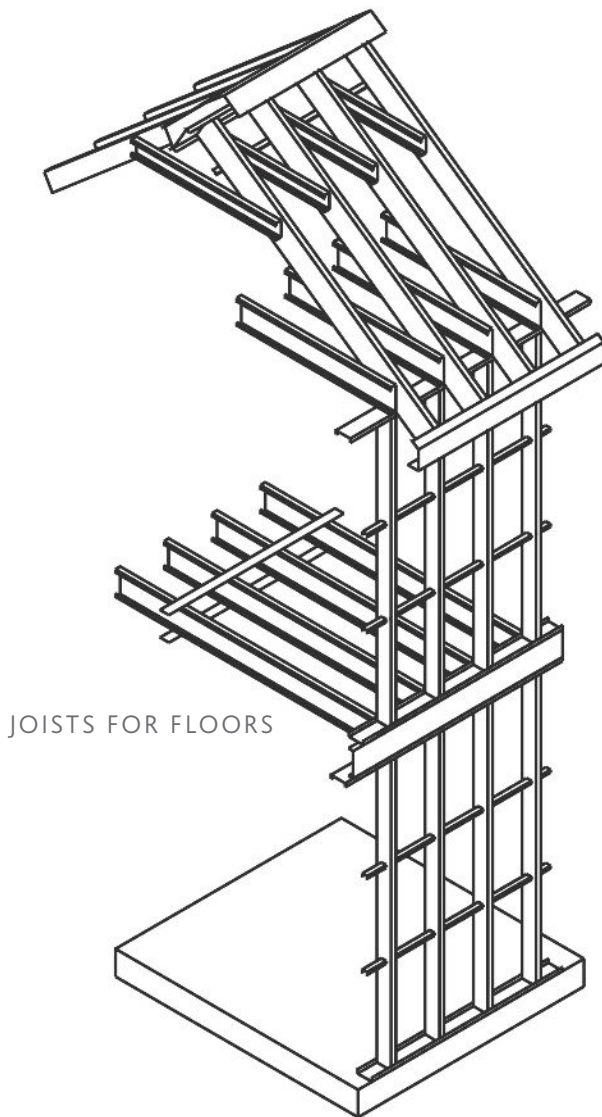

FLOOR JOIST WITH BRIDGING AND BLOCKING

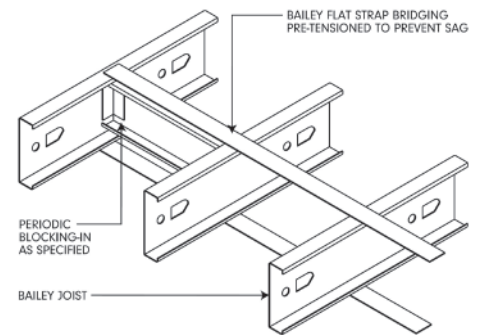

JOISTS CONTINUOUS OVER SUPPORTING BEAM

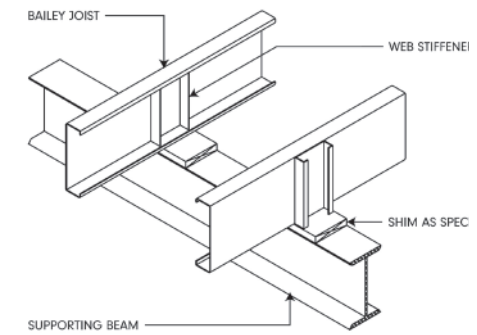

JOIST PARALLEL TO PERIMETER

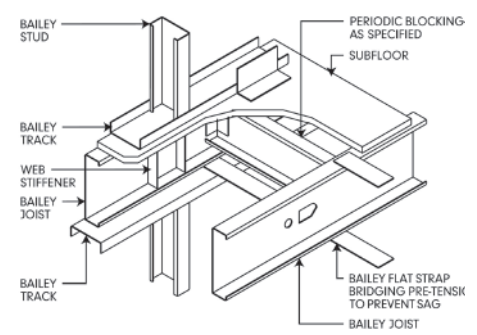



BAILEY

METAL PRODUCTS LIMITED

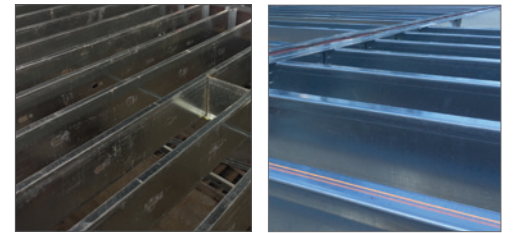

FLOOR MOUNTED INSIDE CONCRETE WALL

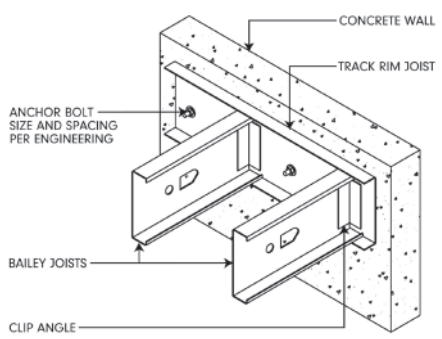

OPENING IN FLOOR

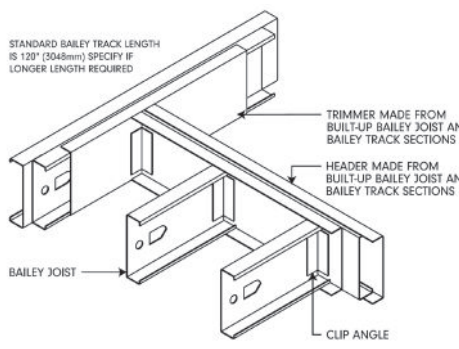

FLUSH CONNECTION TO SUPPORTING BEAM

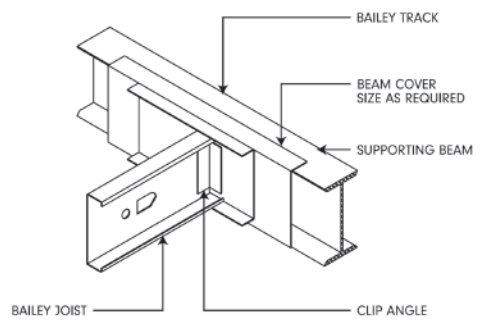

JOISTS OVERLAPPING SUPPORTING BEAM

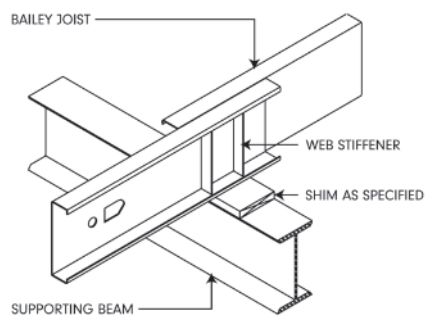

JOIST PERPENDICULAR TO PERIMETER

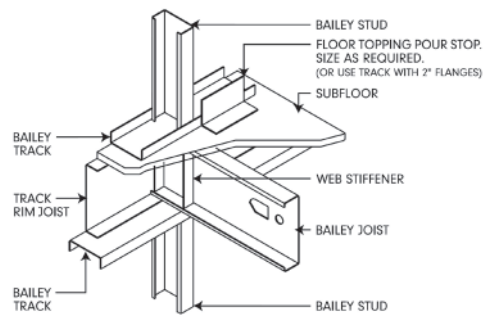

JOIST ABOVE LOADBEARING WALL

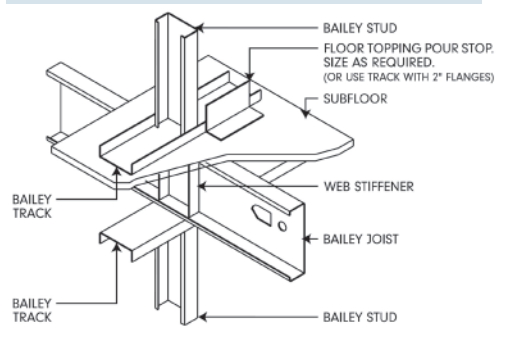

JOIST PERPENDICULAR TO PERIMETER

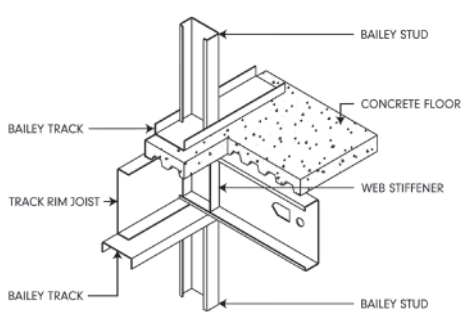

JOIST ABOVE LOADBEARING WALL

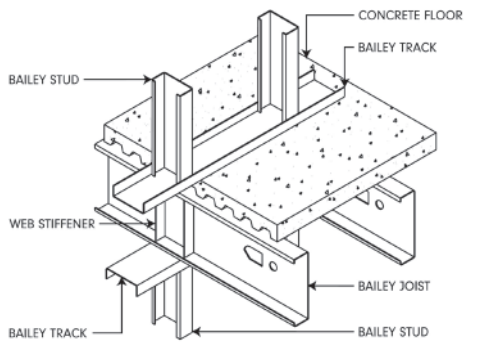

JOIST PARALLEL TO PERIMETER

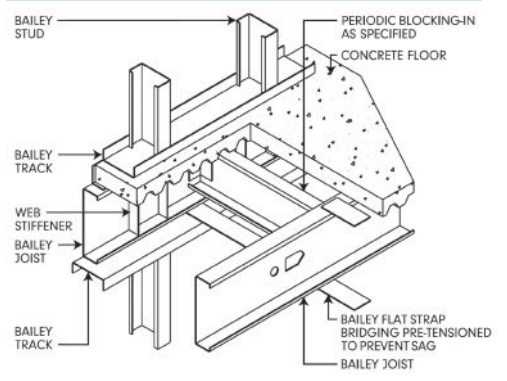

FLOOR JOIST SPAN LIMITATIONS

Joist Member	Yield Strength Fy(ksi)	15 psf Dead Load 40 psf Live Load					
		TL Deflection = L/240, LL Deflection = L/360			TL Deflection = L/240, LL Deflection = L/480		
		Spacing (in) o.c.			Spacing (in) o.c.		
		12	16	24	12	16	24
800S162-43	33	14.9	12.9	10.6	14.9	12.9	10.6
800S162-54	50	18.1	16.5	14.1	16.5	14.9	13.1
800S162-68	50	19.6	17.8	15.6	17.8	16.2	14.2
800S162-97	50	21.8	19.8	17.4	19.8	18	15.7
800S200-43	33	16	13.8	11.3	16	13.8	11.3
800S200-54	50	19.1	17.4	15.1	17.5	15.8	13.8
800S200-68	50	20.6	18.7	16.4	18.7	17	14.8
800S200-97	50	23	20.8	18.1	20.8	18.9	16.5
800S250-43	33	16.4	14.2	11.6	16.4	14.2	11.6
800S250-54	50	19.8	18	15.4	17.9	16.3	14.2
800S250-68	50	21.5	19.5	17	19.5	17.7	15.5
800S250-97	50	24	21.8	19	21.8	19.8	17.2
800S300-43	33	16.6	14.4	11.8	16.6	14.4	11.8
800S300-54	50	20.2	18.3	15.6	18.4	16.7	14.6
800S300-68	50	22	20	17.4	19.9	18.1	15.8
800S300-97	50	24.8	22.5	19.6	22.5	20.4	17.8
1000S162-54	50	21.6	19.1	15.6	19.6	17.8	15.6
1000S162-68	50	23.4	21.3	18.4	21.3	19.3	16.8
1000S162-97	50	26.4	24	20.8	23.9	21.8	18.9
1000S200-54	50	22.6	20.5	16.9	20.5	18.6	16.2
1000S200-68	50	24.4	22.2	19.5	22.2	20.2	17.6
1000S200-97	50	27.5	25	21.8	24.9	22.7	19.8
1000S250-54	50	23.6	21.2	17.3	21.4	19.5	17
1000S250-68	50	25.6	23.2	20.3	23.2	21	18.5
1000S250-97	50	28.7	26	22.8	26.1	23.6	20.7
1000S300-54	50	24	21.6	17.5	21.8	19.8	17.2
1000S300-68	50	26.2	23.8	20.7	23.8	21.6	18.8
1000S300-97	50	29.5	26.8	23.4	26.8	24.4	21.3
1200S162-68	50	27	24.5	20	24.5	22.3	19.5
1200S162-97	50	30.5	27.8	24.2	27.7	25.2	22
1200S200-68	50	28.2	25.6	21.6	25.6	23.2	20.3
1200S200-97	50	32	29	25.2	28.9	26.2	22.9
1200S250-68	50	29	26.5	22.3	26.4	24	20.9
1200S250-97	50	33	30	26.2	30.1	27.3	23.9
1200S300-68	50	30.2	27.5	22.7	27.6	24.9	21.8
1200S300-97	50	34.2	31	27	31.1	28.2	24.6
1400S162-68	50	30	26	21.1	27.6	25.1	21.1
1400S162-97	50	34.6	31.5	27.5	31.5	28.6	24.9
1400S200-68	50	31.7	28.2	23.1	28.7	26.1	22.8
1400S200-97	50	36	32.7	28.6	32.7	29.7	25.9
1400S250-68	50	32.7	29.4	24	29.7	26.9	23.6
1400S250-97	50	37.3	34	29.7	33.9	30.9	26.9
1400S300-68	50	33.3	30	24.5	30.3	27.6	24
1400S300-97	50	38.3	34.7	30.5	34.9	31.7	27.6

1. Spans are based on continuous support of compression flange over the full length of the joist.
2. Joist deflection limitations are based upon L/240 for the total load (TL) and L/360 or L/480 for live load (LL).
3. Joists must be braced against rotation at all supports.
4. The yield stress (33ksi or 50ksi) used to calculate tabulated values is indicated in each table.
5. Span tables are calculated per CSSBI 58-2018 Lightweight Steel Framing Member Selection Tables.
6. Stud distortional buckling based on an assumed $K\phi=0$.
7. Web punchouts are not considered for shear.
8. The tables do not include web crippling calculations. Web crippling and web stiffeners requirements to be designed as per CSSBI 58-2018 and Section G-5 of S136-16.

FLOOR JOIST SPAN LIMITATIONS

Joist Member	Yield Strength Fy(ksi)	25 psf Dead Load 40 psf Live Load					
		TL Deflection = L/240, LL Deflection = L/360			TL Deflection = L/240, LL Deflection = L/480		
		Spacing (in) o.c.			Spacing (in) o.c.		
		12	16	24	12	16	24
800S162-43	33	13.9	12	9.8	13.9	12	9.8
800S162-54	50	17.7	15.9	13	16.5	14.9	13
800S162-68	50	19.1	17.3	15.2	17.8	16.2	14.2
800S162-97	50	21.2	19.3	16.9	19.8	18	15.7
800S200-43	33	14.9	12.9	10.5	14.9	12.9	10.5
800S200-54	50	18.7	16.9	14	17.5	15.8	13.8
800S200-68	50	20.1	18.2	15.9	18.7	17	14.8
800S200-97	50	22.3	20.2	17.7	20.8	18.9	16.5
800S250-43	33	15.3	13.2	10.8	15.3	13.2	10.8
800S250-54	50	19.2	17.5	14.3	17.9	16.3	14.2
800S250-68	50	20.9	18.9	16.5	19.5	17.7	15.5
800S250-97	50	23.3	21.2	18.5	21.8	19.8	17.2
800S300-43	33	15.4	13.4	10.9	15.4	13.4	10.9
800S300-54	50	19.6	17.7	14.5	18.4	16.7	14.5
800S300-68	50	21.4	19.4	16.9	19.9	18.1	15.8
800S300-97	50	24.1	21.9	19.1	22.5	20.4	17.8
1000S162-54	50	20.5	17.7	14.5	19.6	17.7	14.5
1000S162-68	50	22.7	20.7	17.1	21.3	19.3	16.8
1000S162-97	50	25.7	23.3	20.3	23.9	21.8	18.9
1000S200-54	50	21.9	19.1	15.7	20.5	18.6	15.7
1000S200-68	50	23.7	21.6	18.4	22.2	20.2	17.6
1000S200-97	50	26.7	24.3	21.2	24.9	22.7	19.8
1000S250-54	50	22.8	19.7	16.1	21.4	19.5	16.1
1000S250-68	50	24.9	22.6	18.9	23.2	21	18.5
1000S250-97	50	27.9	25.3	22.1	26.1	23.6	20.7
1000S300-54	50	23.1	19.9	16.3	21.8	19.8	16.3
1000S300-68	50	25.5	23.1	19.3	23.8	21.6	18.8
1000S300-97	50	28.7	26.1	22.7	26.8	24.4	21.3
1200S162-68	50	26.2	22.7	18.5	24.5	22.3	18.5
1200S162-97	50	29.7	27.1	23.6	27.7	25.2	22
1200S200-68	50	27.4	24.5	20	25.6	23.2	20
1200S200-97	50	31.1	28.1	24.6	28.9	26.2	22.9
1200S250-68	50	28.3	25.5	20.7	26.4	24	20.7
1200S250-97	50	32.1	29.3	25.5	30.1	27.3	23.9
1200S300-68	50	29.5	25.8	21	27.6	24.9	21
1200S300-97	50	33.2	30.1	26.3	31.1	28.2	24.6
1400S162-68	50	27.8	24.1	19.7	27.6	24.1	19.7
1400S162-97	50	33.6	30.6	25.8	31.5	28.6	24.9
1400S200-68	50	30.4	26.2	21.4	28.7	26.1	21.4
1400S200-97	50	35.1	31.9	27.8	32.7	29.7	25.9
1400S250-68	50	31.6	27.2	22.3	29.7	26.9	22.3
1400S250-97	50	36.4	32.9	28.8	33.9	30.9	26.9
1400S300-68	50	32.2	27.9	22.8	30.3	27.6	22.8
1400S300-97	50	37.2	33.9	29.5	34.9	31.7	27.6

1. Spans are based on continuous support of compression flange over the full length of the joist.
2. Joist deflection limitations are based upon L/240 for the total load (TL) and L/360 or L/480 for live load (LL).
3. Joists must be braced against rotation at all supports.
4. The yield stress (33ksi or 50ksi) used to calculate tabulated values is indicated in each table.
5. Span tables are calculated per CSSBI 58-2018 Lightweight Steel Framing Member Selection Tables.
6. Stud distortional buckling based on an assumed $K\phi=0$.
7. Web punchouts are not considered for shear.
8. The tables do not include web crippling calculations. Web crippling and web stiffeners requirements to be designed as per CSSBI 58-2018 and Section G-5 of S136-16.

FLOOR JOIST SPAN LIMITATIONS

Joist Member	Yield Strength Fy(ksi)	35 psf Dead Load 40 psf Live Load					
		TL Deflection = L/240, LL Deflection = L/360			TL Deflection = L/240, LL Deflection = L/480		
		Spacing (in) o.c.			Spacing (in) o.c.		
		12	16	24	12	16	24
800S162-43	33	13	11.3	9.2	13	11.3	9.2
800S162-54	50	16.9	15	12.3	16.5	14.9	12.3
800S162-68	50	18.2	16.6	14.3	17.8	16.2	14.2
800S162-97	50	20.2	18.5	16.1	19.8	18	15.7
800S200-43	33	13.9	12	9.8	13.9	12	9.8
800S200-54	50	17.8	16.1	13.1	17.5	15.8	13.1
800S200-68	50	19.1	17.4	15.2	18.7	17	14.8
800S200-97	50	21.2	19.3	16.9	20.8	18.9	16.5
800S250-43	33	14.3	12.4	10.1	14.3	12.4	10.1
800S250-54	50	18.3	16.5	13.4	17.9	16.3	13.4
800S250-68	50	19.8	18.1	15.8	19.5	17.7	15.5
800S250-97	50	22.2	20.2	17.6	21.8	19.8	17.2
800S300-43	33	14.5	12.6	10.3	14.5	12.6	10.3
800S300-54	50	18.7	16.7	13.6	18.4	16.7	13.6
800S300-68	50	20.4	18.5	16	19.9	18.1	15.8
800S300-97	50	23	20.8	18.2	22.5	20.4	17.8
1000S162-54	50	19.3	16.7	13.6	19.3	16.7	13.6
1000S162-68	50	21.7	19.7	16.1	21.3	19.3	16.1
1000S162-97	50	24.5	22.2	19.4	23.9	21.8	18.9
1000S200-54	50	20.8	18	14.7	20.5	18	14.7
1000S200-68	50	22.7	20.7	17.2	22.2	20.2	17.2
1000S200-97	50	25.5	23.1	20.2	24.9	22.7	19.8
1000S250-54	50	21.4	18.5	15.1	21.4	18.5	15.1
1000S250-68	50	23.8	21.5	17.7	23.2	21	17.7
1000S250-97	50	26.6	24.1	21.1	26.1	23.6	20.7
1000S300-54	50	21.7	18.7	15.3	21.7	18.7	15.3
1000S300-68	50	24.3	22.1	18	23.8	21.6	18
1000S300-97	50	27.4	25	21.7	26.8	24.4	21.3
1200S162-68	50	24.6	21.3	17.4	24.5	21.3	17.4
1200S162-97	50	28.4	25.8	22.5	27.7	25.2	22
1200S200-68	50	26.1	23	18.8	25.6	23	18.8
1200S200-97	50	29.6	26.8	23.5	28.9	26.2	22.9
1200S250-68	50	27	23.9	19.5	26.4	23.9	19.5
1200S250-97	50	30.8	28	24.4	30.1	27.3	23.9
1200S300-68	50	28	24.2	19.8	27.6	24.2	19.8
1200S300-97	50	31.8	28.8	25.1	31.1	28.2	24.6
1400S162-68	50	26.1	22.6	18.5	26.1	22.6	18.5
1400S162-97	50	32.2	29.2	24.1	31.5	28.6	24.1
1400S200-68	50	28.4	24.6	20.1	28.4	24.6	20.1
1400S200-97	50	33.5	30.4	26.1	32.7	29.7	25.9
1400S250-68	50	29.6	25.6	20.9	29.6	25.6	20.9
1400S250-97	50	34.7	31.6	27	33.9	30.9	26.9
1400S300-68	50	30.2	26.1	21.4	30.2	26.1	21.4
1400S300-97	50	35.6	32.4	27.7	34.9	31.7	27.6

1. Spans are based on continuous support of compression flange over the full length of the joist.
2. Joist deflection limitations are based upon L/240 for the total load (TL) and L/360 or L/480 for live load (LL).
3. Joists must be braced against rotation at all supports.
4. The yield stress (33ksi or 50ksi) used to calculate tabulated values is indicated in each table.
5. Span tables are calculated per CSSBI 58-2018 Lightweight Steel Framing Member Selection Tables.
6. Stud distortional buckling based on an assumed $K\phi=0$.
7. Web punchouts are not considered for shear.
8. The tables do not include web crippling calculations. Web crippling and web stiffeners requirements to be designed as per CSSBI 58-2018 and Section G-5 of S136-16.

FLOOR JOIST SPAN LIMITATIONS

Joist Member	Yield Strength Fy(ksi)	15 psf Dead Load 100 psf Live Load					
		TL Deflection = L/240, LL Deflection = L/360			TL Deflection = L/240, LL Deflection = L/480		
		Spacing (in) o.c.			Spacing (in) o.c.		
		12	16	24	12	16	24
800S162-43	33	10.2	8.8	0	10.2	8.8	0
800S162-54	50	13.4	11.8	9.6	12.2	11	9.6
800S162-68	50	14.5	13.2	11.2	13.2	11.9	10.5
800S162-97	50	16.1	14.7	12.8	14.7	13.3	11.6
800S200-43	33	10.9	9.5	0	10.9	9.5	0
800S200-54	50	14.2	12.6	10.3	12.9	11.7	10.2
800S200-68	50	15.2	13.8	12	13.8	12.6	10.9
800S200-97	50	16.9	15.4	13.5	15.4	13.9	12.2
800S250-43	33	11.2	9.7	0	11.2	9.7	0
800S250-54	50	14.6	12.9	10.6	13.2	12	10.5
800S250-68	50	15.8	14.4	12.3	14.4	13	11.4
800S250-97	50	17.7	16.1	14	16.1	14.6	12.7
800S300-43	33	11.4	9.9	0	11.4	9.9	0
800S300-54	50	14.9	13.1	10.7	13.6	12.3	10.7
800S300-68	50	16.2	14.7	12.6	14.7	13.4	11.7
800S300-97	50	18.3	16.6	14.5	16.6	15.1	13.2
1000S162-54	50	15.1	13.1	10.7	14.5	13.1	10.7
1000S162-68	50	17.3	15.4	12.6	15.7	14.3	12.5
1000S162-97	50	19.4	17.7	15.4	17.6	16	14
1000S200-54	50	16.3	14.1	11.5	15.1	13.7	11.5
1000S200-68	50	18	16.4	13.6	16.4	14.9	13
1000S200-97	50	20.3	18.5	16.1	18.4	16.7	14.6
1000S250-54	50	16.7	14.5	11.8	15.8	14.4	11.8
1000S250-68	50	18.8	17	13.9	17.2	15.6	13.6
1000S250-97	50	21.1	19.2	16.8	19.2	17.5	15.3
1000S300-54	50	17	14.7	12	16.1	14.6	12
1000S300-68	50	19.3	17.3	14.1	17.5	15.9	13.9
1000S300-97	50	21.8	19.8	17.3	19.8	18	15.7
1200S162-68	50	19.3	16.7	13.7	18.1	16.4	13.7
1200S162-97	50	22.6	20.5	17.7	20.5	18.6	16.3
1200S200-68	50	20.8	18.1	14.8	18.8	17.1	14.8
1200S200-97	50	23.5	21.4	18.7	21.4	19.4	16.9
1200S250-68	50	21.5	18.7	15.3	19.5	17.7	15.3
1200S250-97	50	24.4	22.2	19.4	22.2	20.1	17.6
1200S300-68	50	22	19	15.6	20.3	18.4	15.6
1200S300-97	50	25.2	22.9	20	22.9	20.8	18.2
1400S162-68	50	20.5	17.8	14.5	20.4	17.8	14.5
1400S162-97	50	25.5	23.2	18.9	23.2	21.1	18.4
1400S200-68	50	22.3	19.3	15.8	21.2	19.3	15.8
1400S200-97	50	26.6	24.1	20.4	24.1	21.9	19.1
1400S250-68	50	23.2	20.1	16.4	21.9	19.9	16.4
1400S250-97	50	27.5	25	21.2	25	22.7	19.8
1400S300-68	50	23.7	20.5	16.7	22.3	20.3	16.7
1400S300-97	50	28.3	25.7	21.7	25.7	23.3	20.4

1. Spans are based on continuous support of compression flange over the full length of the joist.
2. Joist deflection limitations are based upon L/240 for the total load (TL) and L/360 or L/480 for live load (LL).
3. Joists must be braced against rotation at all supports.
4. The yield stress (33ksi or 50ksi) used to calculate tabulated values is indicated in each table.
5. Span tables are calculated per CSSBI 58-2018 Lightweight Steel Framing Member Selection Tables.
6. Stud distortional buckling based on an assumed $K\phi=0$.
7. Web punchouts are not considered for shear.
8. The tables do not include web crippling calculations. Web crippling and web stiffeners requirements to be designed as per CSSBI 58-2018 and Section G-5 of S136-16.

FLOOR JOIST SPAN LIMITATIONS

Joist Member	Yield Strength Fy(ksi)	25 psf Dead Load 100 psf Live Load					
		TL Deflection = L/240, LL Deflection = L/360			TL Deflection = L/240, LL Deflection = L/480		
		Spacing (in) o.c.			Spacing (in) o.c.		
		12	16	24	12	16	24
800S162-43	33	9.8	8.5	0	9.8	8.5	0
800S162-54	50	13.1	11.4	9.3	12.2	11	9.3
800S162-68	50	14.5	13.2	10.8	13.2	11.9	10.5
800S162-97	50	16.1	14.7	12.8	14.7	13.3	11.6
800S200-43	33	10.6	9.1	0	10.6	9.1	0
800S200-54	50	14.1	12.2	9.9	12.9	11.7	9.9
800S200-68	50	15.2	13.8	11.6	13.8	12.6	10.9
800S200-97	50	16.9	15.4	13.5	15.4	13.9	12.2
800S250-43	33	10.8	9.4	0	10.8	9.4	0
800S250-54	50	14.4	12.5	10.2	13.2	12	10.2
800S250-68	50	15.8	14.4	11.9	14.4	13	11.4
800S250-97	50	17.7	16.1	14	16.1	14.6	12.7
800S300-43	33	10.9	9.5	0	10.9	9.5	0
800S300-54	50	14.6	12.6	10.3	13.6	12.3	10.3
800S300-68	50	16.2	14.7	12.1	14.7	13.4	11.7
800S300-97	50	18.3	16.6	14.5	16.6	15.1	13.2
1000S162-54	50	14.6	12.6	10.3	14.5	12.6	10.3
1000S162-68	50	17.2	14.9	12.2	15.7	14.3	12.2
1000S162-97	50	19.4	17.7	15.4	17.6	16	14
1000S200-54	50	15.7	13.6	11.1	15.1	13.6	11.1
1000S200-68	50	18	16	13.1	16.4	14.9	13
1000S200-97	50	20.3	18.5	16.1	18.4	16.7	14.6
1000S250-54	50	16.2	14	11.3	15.8	14	11.3
1000S250-68	50	18.8	16.4	13.4	17.2	15.6	13.4
1000S250-97	50	21.1	19.2	16.8	19.2	17.5	15.3
1000S300-54	50	16.4	14.2	11.4	16.1	14.2	11.4
1000S300-68	50	19.3	16.7	13.7	17.5	15.9	13.7
1000S300-97	50	21.8	19.8	17.3	19.8	18	15.7
1200S162-68	50	18.6	16.1	13.2	18.1	16.1	13.2
1200S162-97	50	22.6	20.5	17	20.5	18.6	16.3
1200S200-68	50	20.2	17.5	14.2	18.8	17.1	14.2
1200S200-97	50	23.5	21.4	18.3	21.4	19.4	16.9
1200S250-68	50	20.8	18	14.7	19.5	17.7	14.7
1200S250-97	50	24.4	22.2	18.9	22.2	20.1	17.6
1200S300-68	50	21.2	18.4	15	20.3	18.4	15
1200S300-97	50	25.2	22.9	19.4	22.9	20.8	18.2
1400S162-68	50	19.8	17.1	0	19.8	17.1	0
1400S162-97	50	25.5	22.4	18.3	23.2	21.1	18.3
1400S200-68	50	21.5	18.6	15.2	21.2	18.6	15.2
1400S200-97	50	26.6	24.1	19.7	24.1	21.9	19.1
1400S250-68	50	22.4	19.4	15.8	21.9	19.4	15.8
1400S250-97	50	27.5	25	20.5	25	22.7	19.8
1400S300-68	50	22.9	19.8	16.2	22.3	19.8	16.2
1400S300-97	50	28.3	25.7	20.9	25.7	23.3	20.4

1. Spans are based on continuous support of compression flange over the full length of the joist.
2. Joist deflection limitations are based upon L/240 for the total load (TL) and L/360 or L/480 for live load (LL).
3. Joists must be braced against rotation at all supports.
4. The yield stress (33ksi or 50ksi) used to calculate tabulated values is indicated in each table.
5. Span tables are calculated per CSSBI 58-2018 Lightweight Steel Framing Member Selection Tables.
6. Stud distortional buckling based on an assumed $K\phi=0$.
7. Web punchouts are not considered for shear.
8. The tables do not include web crippling calculations. Web crippling and web stiffeners requirements to be designed as per CSSBI 58-2018 and Section G-5 of S136-16.

FLOOR JOIST SPAN LIMITATIONS

Joist Member	Yield Strength F _y (ksi)	35 psf Dead Load 100 psf Live Load					
		TL Deflection = L/240, LL Deflection = L/360			TL Deflection = L/240, LL Deflection = L/480		
		Spacing (in) o.c.			Spacing (in) o.c.		
		12	16	24	12	16	24
800S162-43	33	9.5	8.3	0	9.5	8.3	0
800S162-54	50	12.7	11	8.9	12.2	11	8.9
800S162-68	50	14.5	12.8	10.5	13.2	11.9	10.5
800S162-97	50	16.1	14.7	12.8	14.7	13.3	11.6
800S200-43	33	10.2	8.8	0	10.2	8.8	0
800S200-54	50	13.6	11.8	9.6	12.9	11.7	9.6
800S200-68	50	15.2	13.8	11.2	13.8	12.6	10.9
800S200-97	50	16.9	15.4	13.5	15.4	13.9	12.2
800S250-43	33	10.5	9.1	0	10.5	9.1	0
800S250-54	50	13.9	12	9.8	13.2	12	9.8
800S250-68	50	15.8	14.1	11.5	14.4	13	11.4
800S250-97	50	17.7	16.1	14	16.1	14.6	12.7
800S300-43	33	10.6	9.2	0	10.6	9.2	0
800S300-54	50	14.1	12.2	10	13.6	12.2	10
800S300-68	50	16.2	14.3	11.7	14.7	13.4	11.7
800S300-97	50	18.3	16.6	14.5	16.6	15.1	13.2
1000S162-54	50	14.1	12.2	10	14.1	12.2	10
1000S162-68	50	16.6	14.4	11.8	15.7	14.3	11.8
1000S162-97	50	19.4	17.7	15	17.6	16	14
1000S200-54	50	15.2	13.2	10.7	15.1	13.2	10.7
1000S200-68	50	17.9	15.5	12.6	16.4	14.9	12.6
1000S200-97	50	20.3	18.5	16.1	18.4	16.7	14.6
1000S250-54	50	15.6	13.5	10.9	15.6	13.5	10.9
1000S250-68	50	18.4	15.9	13	17.2	15.6	13
1000S250-97	50	21.1	19.2	16.6	19.2	17.5	15.3
1000S300-54	50	15.8	13.7	10.9	15.8	13.7	10.9
1000S300-68	50	18.7	16.2	13.2	17.5	15.9	13.2
1000S300-97	50	21.8	19.8	16.9	19.8	18	15.7
1200S162-68	50	18	15.6	12.7	18	15.6	12.7
1200S162-97	50	22.6	20.2	16.5	20.5	18.6	16.3
1200S200-68	50	19.5	16.9	13.8	18.8	16.9	13.8
1200S200-97	50	23.5	21.4	17.7	21.4	19.4	16.9
1200S250-68	50	20.2	17.5	14.3	19.5	17.5	14.3
1200S250-97	50	24.4	22.2	18.3	22.2	20.1	17.6
1200S300-68	50	20.5	17.7	14.5	20.3	17.7	14.5
1200S300-97	50	25.2	22.9	18.7	22.9	20.8	18.2
1400S162-68	50	19.1	16.6	0	19.1	16.6	0
1400S162-97	50	25	21.7	17.7	23.2	21.1	17.7
1400S200-68	50	20.8	18	14.7	20.8	18	14.7
1400S200-97	50	26.6	23.4	19.1	24.1	21.9	19.1
1400S250-68	50	21.6	18.7	15.3	21.6	18.7	15.3
1400S250-97	50	27.5	24.2	19.8	25	22.7	19.8
1400S300-68	50	22.1	19.2	15.4	22.1	19.2	15.4
1400S300-97	50	28.3	24.8	20.3	25.7	23.3	20.3

1. Spans are based on continuous support of compression flange over the full length of the joist.
2. Joist deflection limitations are based upon L/240 for the total load (TL) and L/360 or L/480 for live load (LL).
3. Joists must be braced against rotation at all supports.
4. The yield stress (33ksi or 50ksi) used to calculate tabulated values is indicated in each table.
5. Span tables are calculated per CSSBI 58-2018 Lightweight Steel Framing Member Selection Tables.
6. Stud distortional buckling based on an assumed $K\phi=0$.
7. Web punchouts are not considered for shear.
8. The tables do not include web crippling calculations. Web crippling and web stiffeners requirements to be designed as per CSSBI 58-2018 and Section G-5 of S136-16.



BAILEY[®]

METAL PRODUCTS LIMITED

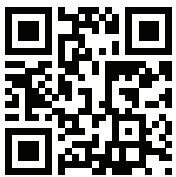

BAILEY C JOIST SPAN TABLES AND DETAILS

sales@bmp-group.com • www.bmp-group.com



JF07IN19-1000

MONTREAL

525 Avenue Edward VII
Dorval, QC H9P 1E7
Tel. (514) 735-3455
800-263-3455
Fax. (514) 735-5052

TORONTO

1 Caldari Road
Concord, ON L4K 3Z9
Tel. (905) 738-9267
800-668-2154
Fax. (905) 738-5712

CALGARY

3924 27th Street NE
Calgary, AB T1Y 5K7
Tel. (403) 248-3536
800-665-2013
Fax. (403) 248-0288

EDMONTON

5710 Roper Road NW
Edmonton, AB T6B 3G7
Tel. (780) 462-5757
800-563-1751
Fax. (780) 450-3378

VANCOUVER

7715 Anvil Way
Surrey, BC V3W 6A2
Tel. (604) 590-5100
800-818-2666
Fax. (604) 590-5105